

NOTES:

1. Precast Manholes are Fabricated to meet or Exceed the Following Specifications:
 - Manhole: ASTM C-478 Latest AASHTO M-199,
 - Wall: ASTM A-185,
 - Base: ASTM 615, Grade 60.
2. Concrete Compressive Strength = 4,000psi.
3. Precast Meets ASTM C913.
4. All Manhole Sections are Designed for HS20 Loading (NCDOT #840.52).
5. Limit Depth of Fill to 30'-0" from Finish Grade to Top of Inside Floor.
6. All Joints Conform to ASTM C990.
7. Joint Sealant: Butyl Rubber SS-S-00210.
8. Co-Polymer Polypropylene Steel Reinforced Steps meet ASTM-C478 Latest.
9. Wall Reinforcing Minimum of 0.12 SQ IN. per Linear Foot each Way.
10. Manhole Base Reinforced Both Ways with a Minimum Area of 0.12 SQ IN. per Linear Foot each Way.
11. All Cast Holes are Additionally Reinforced with #4 Rebar Grade 60.
12. All Pipe Openings to be no Greater than 3" Larger than Outside Diameter of Pipe and Additionally Reinforced with a Minimum of 0.20 SQ IN. of Steel at 90 Degrees. Additional Reinforcing not Required for Cored Openings.

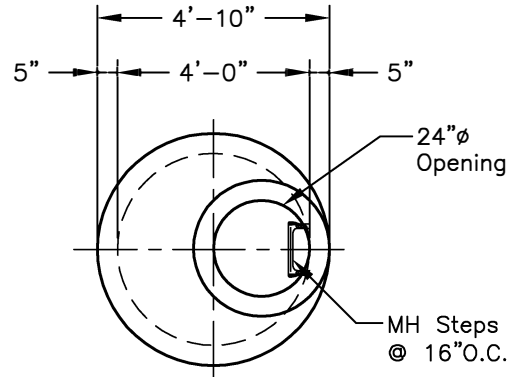

PLAN VIEW

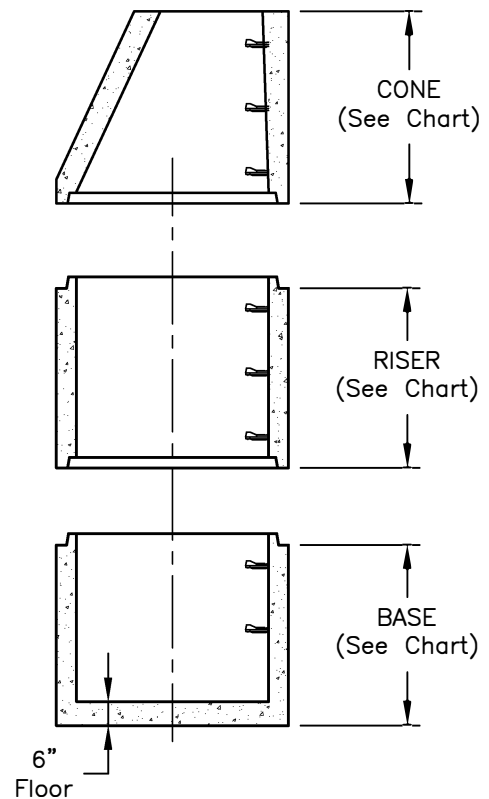

SECTION VIEW

ITEM	HEIGHT	WT (LBS)
CONE	20"	1,460
	36"	2,720
	48"	3,620
RISER	12"	880
	16"	1,180
	32"	2,340
	48"	3,520
BASE	24"	2,900
	28"	3,190
	32"	3,480
	36"	3,780

4' DIAMETER SEWER MANHOLE

DATE: Apr 2011 REV: ** SCALE: 1/4"=1'-0"